



INSTALLATION & MAINTENANCE MANUAL

OL01B / OL01P

GENERAL INSTRUCTIONS

These instructions should be read carefully and retained after installation by the end user for future reference and maintenance.

**These instructions should be used to aid installation of the following products:
OL01B / OL01P**

SAFETY

- This product must be installed in accordance with the latest edition of the IEE Wiring Regulations (BS7671) and current Building Regulations. If in any doubt, consult a qualified electrician
- Please isolate mains prior to installation or maintenance
- Check the total load on the circuit (including when this luminaire is fitted) does not exceed the rating of the circuit cable, fuse or circuit breaker
- Please note the IP (Ingress Protection) rating of this luminaire when deciding the location for installation
- This product is Class I and must be earthed
- This product series is IP54 rated

INSTALLATION

Note - If this luminaire is being used in conjunction with an external PIR or sensor, please confirm with the manufacturer of the sensors that they are compatible with LED lamps

- Provide power to the required point of installation (refer to BS7671 for correct cabling methods)
- Suitable IP rated junction boxes should be used where required
- The luminaire should not be installed in areas where there is a high risk of flooding
- Round cable should be used for the mains supply. The use of flat cable will cause water ingress to the fitting. The luminaire is supplied with an IP68 inline connector allowing the termination of one 3-core flex up to 1.5mm²
- If fixing into fresh concrete: screw the rods into the fixing plate leaving between 12–16mm of thread above the surface and set it into the wet concrete (see Fig. 1)

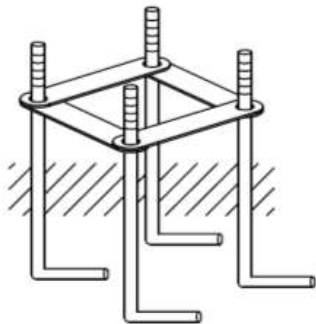

Fig. 1

- Remove the baseplate from the luminaire by loosening the screws on the sides
- When the concrete is set, fix the baseplate to the threaded rods using the spring washers and nuts provided (see Fig. 2)
- If fixing onto solid surface: using the baseplate as a template, mark the location for, and drill the fixing holes ensuring not to infringe with any gas/water pipes or electrical cables. Fix the baseplate using suitable fixings (not provided)
- Connect the luminaire to the mains supply ensuring the correct polarity is observed: Live (brown), Earth (green/yellow), Neutral (blue) (see Fig. 3)

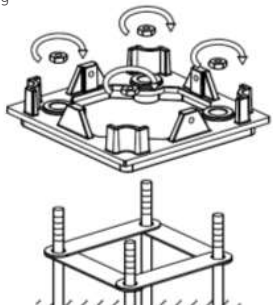

Fig. 2

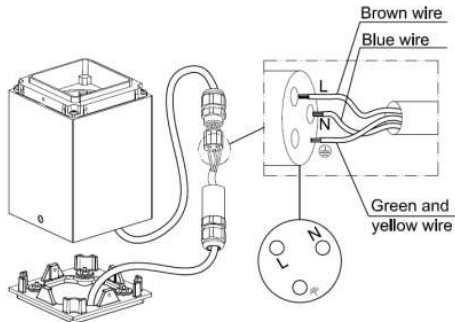

Fig. 3

- Tighten the compression gland ensuring a tight seal is made
- Refit the luminaire to the baseplate and tighten
- Remove the top of the luminaire by loosening the two Allen screws on the sides and insert a suitable E27 lamp (max. 20W)
- Switch on and check for correct operation

WARNING

This product is not suitable for installation in or near a coastal or marine environment.

GENERAL

This product should be recycled in the correct manner when it reaches the end of its life. Check local authorities for where facilities exist.

Clean the external surfaces with a damp cloth using a mild solution of detergent and warm water only, do not use aggressive cleaning products or solvents which may damage the product.

Do not use any source of high-pressure washers to maintain or clean this luminaire.

This product is dimmable dependent on lamp type.

WARRANTY

This product has a warranty of 2 years from date of purchase. Failure to install this product in accordance with the current edition of the IEE Wiring Regulations (BS7671), improper use, or removal of the batch code will invalidate the warranty. If this product should fail within its warranty period, it should be returned to the place of purchase for a free of charge replacement. ML Accessories does not accept responsibility for any installation costs associated with the replacement product. Your statutory rights are not affected. ML Accessories reserve the right to alter product specification without prior notice.



IP54

ML
ACCESSORIES LTD



**UK
CA**

CE



136

ML Accessories Limited LU5 4LT
www.mlaccessories.co.uk

**INTERNATIONAL
CONTACT DETAILS**

