



INSTALLATION & MAINTENANCE MANUAL

MODMWS110

GENERAL INSTRUCTIONS

**These instructions should be read carefully and retained after installation by the end user for future reference and maintenance. These instructions should be used to aid installation of the following product:
MODMWS110**

SAFETY

- This product must be installed in accordance with the latest edition of the IEE Wiring Regulations (BS7671) and current Building Regulations. If in any doubt, consult a qualified electrician
- Please isolate mains prior to installation or maintenance
- Check the total load on the circuit (including when this product is fitted) does not exceed the rating of the circuit cable, fuse or circuit breaker
- Please note the IP (Ingress Protection) rating of these products when deciding the location for installation
- Do not overload this accessory or subject it to conditions outside its rating
- This product is for indoor use only
- This products ais Class II double insulated
- This product is IP20 rated

INSTALLATION

For a comprehensive list of compatible products, please visit the official ML Accessories website at www.mlaccessories.co.uk and refer to the relevant page

Note - Microwave sensors may not be suitable for all installations, for example enclosed spaces, as they are able to detect movement through non-metallic surfaces like plasterboard and thin doors.

MODMWS110

- Install the sensor using the clips to secure them in place
- Luminaire with no emergency mode and sensor connected, connect the connectors labelled A from the terminal block to A(S) from the sensor and connector labelled B from the driver to B(S) from sensor
- See Fig. 1 for wiring diagram

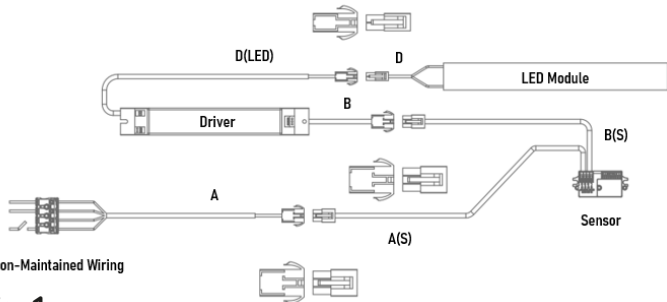
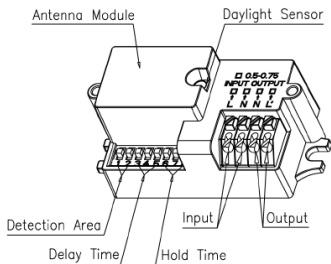



Fig. 1

SENSOR LAYOUT



Detection Area



1	2	
●	●	100%
●	○	75%
○	●	50%
○	○	25%

Hold Time



3	4	5	
●	●	●	5sec
●	●	○	30sec
●	○	●	1min
●	○	○	3min
○	●	●	5min
○	●	○	10min
○	○	●	20min
○	○	○	30min

This is the time period the lamp remains at 100% after no motion is detected

Daylight Sensor



6	7	8	
●	●	●	2lx
●	●	○	10lx
○	●	○	25lx
●	○	○	50min
○	○	○	*Disable

When set to disable, the daylight sensor will switch to lamp on when motion is detected regardless of the ambient light level

MODEMKIT2110 and MODMWS110

- Install the **MODEMKIT2110** and **MODMWS110** by using the clips to secure them in place
- Luminaire with emergency mode and sensor connected, connect the connectors labelled **A** from the terminal block to **A(EM)** from the emergency module, connector labelled **A(S)** from sensor to connector labelled **B(EM)** from emergency module, connector labelled **B** from the driver to **B(S)** from sensor, connector labelled **C(LED)** from emergency module to **C** LEDs and connectors labelled **D(LED)** from emergency module to **D** LEDs

- Ensure that the battery is connected which is within the emergency module and the battery connector on the PCB
- Ensure LED indicator is connected, mounted on holder located on end cap correctly and visible from outside
- See Fig. 2 for wiring diagram

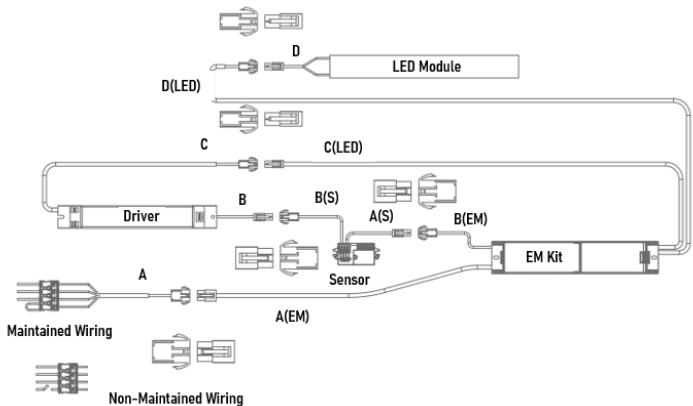

Fig. 2

NOTE: The **MODEMKIT2110** and **MODMWS110** is sold separately

WARNING

This product must be disconnected from the circuit if subjected to any high voltage or insulation resistance testing. Irreparable damage will occur if this instruction is not followed.

GENERAL

This product should be recycled in the correct manner when it reaches the end of its life. Check local authorities for where facilities exist.

WARRANTY

This product has a warranty of 5 years from date of purchase. Failure to install this product in accordance with the current edition of the IEE Wiring Regulations (BS7671), improper use, or removal of the batch code will invalidate the warranty. If this product should fail within its warranty period, it should be returned to the place of purchase for a free of charge replacement. ML Accessories does not accept responsibility for any installation costs associated with the replacement product. Your statutory rights are not affected. ML Accessories reserve the right to alter product specification without prior notice.



Manufacturers Declaration of Conformity
For ML Accessories (Knightsbridge)
Electrical products in accordance with UKCA marking

ML Accessories Ltd. declare that all products have been designed, manufactured, and tested in accordance with the requirements of the relevant legislation

UKCA marking legislation

UK SI 2016 No. 1091	Electro Magnetic Compatibility Regulations 2016
UK SI 2016 No. 1101	The Electrical Equipment (Safety) Regulations 2016
UK SI 2012 No. 3032	Restriction of the use of Certain Hazardous Substances in Electrical and Electronic Equipment Regulations 2012
UK SI 2017 No. 1206	Radio Equipment regulations 2017
UK SI 2021 No. 1095	The Ecodesign for Energy-Related Products and Energy Information (Lighting Products) Regulations 2021

Included Legislation

UK SI 2008 No. 2852	UK REACH
UK SI 2013 No. 3113	WEEE

Safety Standards

Full individual declarations and specific safety standards applicable to relevant product series can be found on our website www.mlaccessories.co.uk

We hereby declare that the equipment named above has been designed to comply with the relevant sections of the above referenced specifications. The products comply with all essential requirements of the directives.

Dave Dawkins
CEO

Kevin Stubbs FSLL
Head of Technical



ML Accessories Ltd. Unit E Chiltern Park, Boscombe Road, Dunstable. Bedfordshire, LU5 4LT



Manufacturers Declaration of Conformity
For ML Accessories (Knightsbridge)
Electrical products in accordance with CE marking

ML Accessories Ltd. Declare that all products have been designed, manufactured, and tested in accordance with the requirements of the relevant legislation

CE marking legislation

In Accordance with the following Directives:

2014/35/EU	Low Voltage Directive
2014/30/EU	EMC Directive
2014/53/EU	Radio Equipment Directive

Including Legislation

1907/2006	REACH
2015/863	RoHS
2021/341	ERP

Safety Standards

Full individual declarations and specific safety standards applicable to relevant product series can be found on our website www.mlaccessories.co.uk

We hereby declare that the equipment named above has been designed to comply with the relevant sections of the above referenced specifications. The product complies with all essential requirements of the directives.

Dave Dawkins
CEO

Kevin Stubbs FSLL
Head of Technical



ML Accessories Ltd. Unit E Chiltern Park, Boscombe Road, Dunstable. Bedfordshire, LU5 4LT

SUPPLIED BY:

(UK) MANUFACTURER

ML ACCESSORIES LTD, UNIT E CHILTERN PARK,
BOSCOMBE ROAD, DUNSTABLE LU5 4LT,
WWW.MLACCESSORIES.CO.UK

(EU) AUTHORISED REPRESENTATIVE

SLV LIGHTING GROUP,
DAIMLERSTRASSE 21-23,
52531 ÜBACH-PALENBERG, GERMANY
EMAIL: EPREL@GROUP.SLV.COM

MADE IN CHINA

110V
50Hz



IP20

20~
50°C
TA



ML
ACCESSORIES LTD



UK
CA



134