



INSTALLATION & MAINTENANCE MANUAL

**MODEMKIT2110**

## GENERAL INSTRUCTIONS

### INSTALLATION & MAINTENANCE MANUAL

**These instructions should be read carefully and retained after installation by the end user for future reference and maintenance.**

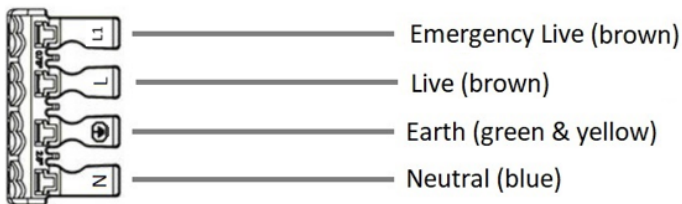
**These instructions should be used to aid installation of the following products:  
MODEMKIT2110**

## SAFETY

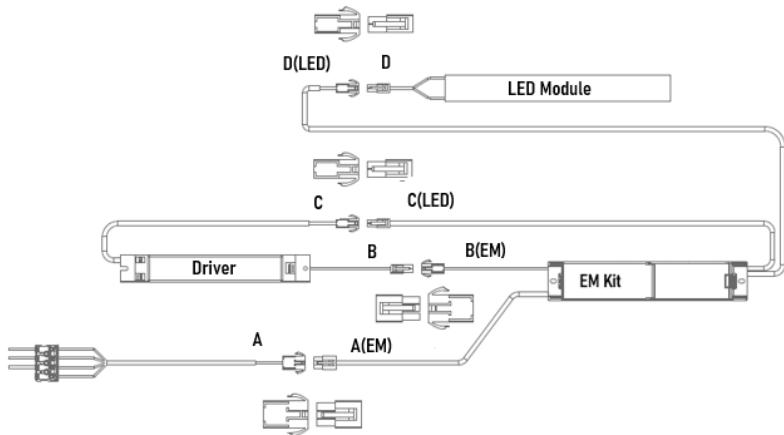
- This product must be installed in accordance with the latest edition of the IEE Wiring Regulations (BS7671) and current Building Regulations. If in any doubt, consult a qualified electrician
- Please isolate mains prior to installation or maintenance
- Check the total load on the circuit (including when this product is fitted) does not exceed the rating of the circuit cable, fuse or circuit breaker
- Please note the IP (Ingress Protection) rating of this product when deciding the location for installation
- Do not overload this accessory or subject it to conditions outside its rating
- This product is for indoor use only
- This product is Class II
- This product is IP20 rated

## INSTALLATION

- Ensuring correct polarity is observed, carefully wire as shown in Fig. 1 for suitable modular fitting. Two cables can be inserted into the push-fit terminal block in order to achieve loop-in/loop-out wiring

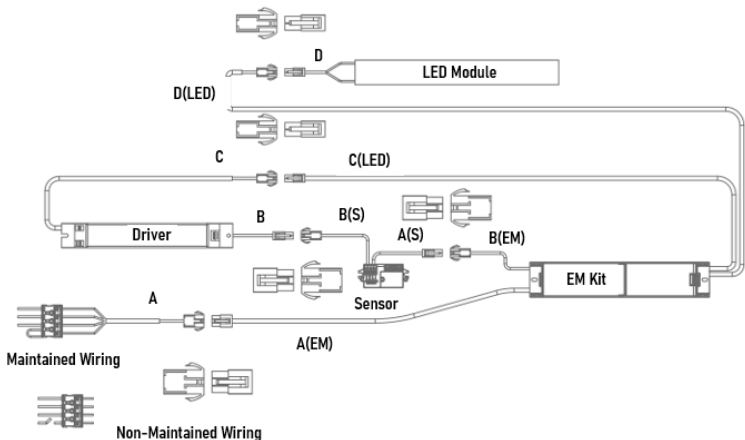


**Fig. 1**



## MODEMKIT2110

- Install by using the clips to secure them in place
- Luminaire with emergency mode and no sensor connected, connect the connectors labelled A from the terminal block to A(EM) from the emergency module, connector labelled B from the driver to B(EM) emergency module, connector labelled C(LED) from emergency module to C LEDs and connectors labelled (DLED) from emergency module to D LEDs
- Ensure that the battery is connected by opening the emergency module pack and the battery connector on the PCB
- Ensure LED indicator is connected, mounted on holder located on end cap correctly and visible from outside
- Select the testing method, manual or self-test, using the switch on the front of the kit.



## MODEMKIT2110 & MODMWS110

- Install the MODEMKIT2110 and MODMWS110 by using the clips to secure them in place
- Luminaire with emergency mode and sensor connected, connect the connectors labelled A from the terminal block to A(EM) from the emergency module, connector labelled A(S) from sensor to connector labelled B(EM) from emergency module, connector labelled B from the driver to B(S) from sensor, connector labelled C(LED) from emergency module to C LEDs and connectors labelled D(LED) from emergency module to D LEDs
- Ensure that the battery is connected which is within the emergency module and the battery connector on the PCB
- Ensure LED indicator is connected, mounted on holder located on end cap correctly and visible from outside
- Select the testing method, manual or self-test, using the switch on the front of the kit.

**NOTE:** The **MODMWS110** are sold separately

- Refasten the cover
- Switch on and check for correct operation ensuring the green indicator LED is illuminated
- We recommend, on commissioning the installation, a minimum charge period of 24 hours before carrying out an emergency duration test
- The test button can be used to simulate a power failure to test the lamp and battery operation. This can be used to carry out monthly functional testing providing the battery holds at least a small charge

### **Commissioning**

- Commissioning takes place by connecting the battery and then the un-switched supply. The battery must be connected first
- The green LED indicator will immediately flash 1 x second to indicate that there is a pending duration test
- A functional test will occur at 5 minutes after commissioning to allow 5 minutes for battery charging to ensure there is some charge
- A duration test will occur at between 24 - 48 hours after commissioning
- Any faults found in the functional and duration testing will be reported by the LED indicator as detailed below
- Disconnecting the un-switched supply and the battery resets the emergency module, clears all faults and a re-commission when the battery and then the un-switched supply are reconnected
- If the un-switched supply of an emergency lighting circuit is switched ON/OFF twice within 5 seconds, the schedule for all the emergency units in the circuit will reset to the currenttime

### **Duration Testing (3 hours)**

- An automatic duration test will occur between 24–48 hours after commissioning to allow for battery charging
- An automatic duration test will occur semi-annually or annually at a random point in the 52nd week of each year
- A duration test will occur at a random point between 0–24 hours after pressing the manual button for 5–10 seconds. Time will be added to allow the battery to charge if the battery has been charging for less than 24 hours
- A duration test may be delayed by other events, such as a power cut that interrupts the test or a lack of charging time to the battery. If this occurs, the green LED indicator will flash 1 x second to indicate there is a pending duration test and the emergency module has been rescheduled
- Any faults found in the duration testing will be reported via the LED indicator, as detailed below
- A functional test will not override any faults reported by a duration test. A full duration test or re commissioning is required to clear any faults

### **Functional Testing (<2 minutes)**

- A short automatic functional test will occur every 7 days
- A manual functional test will start after pressing the manual test button to 1 – 2 seconds
- Any faults found in the functional testing will be reported by the LED indicator, as detailed below
- A functional test will not override any faults reported by a duration test. A full duration test or re commissioning is required to clear any faults

### **Manual Testing**

- For a manual functional test, press the test button for 1–2 seconds. A manual functional test will last <2 minutes will start
- For a manual duration test, press the test button for 5–10 seconds. A manual duration test will occur at a random point between 0–24 hours after pressing the test button for 5–10 seconds. Time will be added to allow the battery to charge if the battery has been charging for less than 24 hours

### **Pending Duration Testing**

- A duration test maybe delayed by other events, such as power cut that interrupts the test or charging period. If this occurs, the green LED indicator will flash to indicate there is a pending duration test and the emergency module has been rescheduled until charging is complete

### **Lamp or Luminaire Fault**

- Turn off the supply and replace or correct the fault with the lamp or luminaire, and then reconnect the supply
- Press the manual test button for 5–10 seconds. A manual duration test will occur at a random point between 24–48 hours later to allow the battery to charge fully
- If the battery and power have been disconnected, the EM kit will re-commission and automatically test the replacement
- A successful functional test will not override any faults reported by a duration test. A full duration test or re-commissioning is required to clear any faults

### Battery Fault

- Turn off the un-switched supply to the EM kit and replace the battery, then reconnect the supply
- If the fault was because the battery was not connected, the un-switched supply must be turned off when connecting the battery to clear the battery fault
- The EM kit will re-commission and automatically test the replacement between 24 – 48 hours after commissioning to allow for battery charging

### LED Indicator

- System status is indicated by a bi-colour indicator LED as detailed below

LED Indication	Status
Green permanently ON	System Healthy
Permanently OFF	Emergency mode: Mains failure or mains disconnected
Green Flash 1 x second	Duration Test Pending
Green Flash 2 x second	Duration Test Running
Green Fast Flash 4 x second	Functional Test Running
Red Permanently ON	Battery Charging Fault
Red Flash 2 x second	Battery Duration Fault
Red Flash 4 x second	Lamp or Luminaire Fault

## **WARNING**

This product must be disconnected from the circuit if subjected to any high voltage or insulation resistance testing. Irreparable damage will occur if this instruction is not followed.

## **GENERAL**

Clean with a soft dry cloth only, do not use aggressive cleaning products or solvents which may damage the product.

Installing in areas where the temperature consistently drops below 0°C may shorten the battery life.

The maximum constant ambient temperature at the point of installation should not exceed 50°C.

The battery in this product is Lithium Ion and must be disposed of correctly. Please contact the local authorities for the disposal of this toxic waste.

## WARRANTY

This product has a warranty of 5 years (including battery) from date of purchase. Failure to install this product in accordance with the current edition of the IEE Wiring Regulations (BS7671), improper use, or removal of the batch code will invalidate the warranty. If this product should fail within its warranty period, it should be returned to the place of purchase for a free of charge replacement. ML Accessories does not accept responsibility for any installation costs associated with the replacement product. Your statutory rights are not affected. ML Accessories reserve the right to alter product specification without prior notice.

## TESTING FOR EMERGENCY LUMINAIRES

Recommended routine test procedure in accordance with BS5266:

- Daily check – check status of bi-colour LED indicator
- Monthly functional test – the luminaire will perform this function without any action from the user. Alternatively, simulate a mains supply failure for approx. 30 seconds by operation of key switch, switching off circuit breaker or using test button. Ensure normal supply is restored after test and check status of bi-colour LED indicator
- Annual 3-hour duration test – the luminaire will perform this function without any action from the user. Alternatively, simulate a mains supply failure for 3-hour continuous test by operation of key switch, switching off circuit breaker or using test button. Ensure normal supply is restored after test and check status of bi-colour LED indicator
- If the luminaire fails any of the above tests, please contact a qualified electrician. Results should be recorded, even when obtained via the self-test function. See below for test record sheet

**TEST RECORD SHEET**

INITIAL COMMISSIONING 3 HOUR TEST		SIGNED				DATE					
		FIRST YEAR		SECOND YEAR		THIRD YEAR		FOURTH YEAR		FIFTH YEAR	
MONTH	TEST	SIGNED	DATE	SIGNED	DATE	SIGNED	DATE	SIGNED	DATE	SIGNED	DATE
1	FUNCTIONAL										
2	FUNCTIONAL										
3	FUNCTIONAL										
4	FUNCTIONAL										
5	FUNCTIONAL										
6	FUNCTIONAL										
7	FUNCTIONAL										
8	FUNCTIONAL										
9	FUNCTIONAL										
10	FUNCTIONAL										
11	FUNCTIONAL										
12	3 HOUR										

Installed by:

Installation date:

Contact number:

**SUPPLIED BY:**

**(UK) MANUFACTURER**

**ML ACCESSORIES LTD**, UNIT E CHILTERN PARK,  
BOSCOMBE ROAD, DUNSTABLE LU5 4LT,  
[WWW.MLACCESSORIES.CO.UK](http://WWW.MLACCESSORIES.CO.UK)

**(EU) AUTHORISED REPRESENTATIVE**

**SLV LIGHTING GROUP**,  
DAIMLERSTRASSE 21-23,  
52531 ÜBACH-PALENBERG, GERMANY  
**EMAIL:** [EPREL@GROUP.SLV.COM](mailto:EPREL@GROUP.SLV.COM)

MADE IN CHINA

**110V**  
**50Hz**



**IP20**

**0~**  
**45°C**  
**TA**



**ML**  
ACCESSORIES LTD



**UK**  
**CA**



**134**

SMOCT25\_V1